



User Instructions issue 1.0 March 2005

Product overview

The Pixelline 110ec is a high brightness linear wash device.

The Pixelline 110ec comprises of five cells of luxeon emitters. Each cell uses five blue and green 3 watt luxeon emitters and 6 red and amber 1 watt luxeon emitters, designed to produce a standard beam angle of six degrees. The beam of light projects no radiated heat forwards and what little heat is generated is dissipated via our unique (patent pending) heat management system.

Light emitting diodes produce substantially less heat when compared to conventional lamps. There is inevitably a certain amount of heat generated in the process of conversion of electrical energy to visible light.

All Pixel Range products feature a patent pending thermal management system that has been designed to ensure that the LED's are run within their normal operating envelope, optimising performance.

DMX control desk personalities are now available from our website for download from discerning console manufacturers. This gives the designer great flexibility in achieving new lighting looks from this product. Please contact us if there is a desk personality that is not on the download list.

The Pixelline 110ec can be flush connected end to end to produce a very low profile continuous emission of light with no break in the led pattern from fitting to fitting. Ideal for cyc or wall wash illumination. A combination (combi) floor and rig mounted yoke provides easy setup with a variety of different applications.

Typically up to an 85% or higher reduction in electrical consumption is possible. With cost savings made from reduced air conditioning costs in dissipating the heat from conventional high wattage lights.

The Pixel range comes equipped with a built in powerful micro processor, various internal programs and mode adjustments can be performed via the universal user interface, which is equipped on all the pixel products. This user interface has an intuitive logic, facilitating easy set-up. This interface has a four digit alphanumeric display and four status indicators.

Menu Access

Overview

It is possible to set-up different operating modes by using the user interface (located top centre). This interface allows access to the different built in functions performed by the on-board microprocessor.

The four digit alpha numeric displays menu and function information. Four blue leds provide status information on power, data present, master and slave mode.

Pressing each of the four recessed switches located directly under the alphanumeric display performs access to the various functions.

Tip, The product is shipped, factory set to DMX address 001. The alphanumeric display fades out after 30 seconds, the display will illuminate when the menu key is pressed once.

Computer menus

- **To gain access to the following menu pages, press [menu] once, then use the up or down arrow to select the desired page.**
- **Once you have scrolled to the desired menu page, press [enter] once**
- **scroll to the desired sub menu and press [enter] once**
- **To adjust the function, use the up and down arrows, then press [enter] once**
- **Press [menu] once to return to your previous position**

Factory reset;

When showing dmX address, press two centre buttons together, this resets device to dmX mode address 001, and mint off, highest resolution setting.

The reset also resets the internal effects generator back to default levels, including any stored speed, slope and chase sequences.

Menu flow chart

Please pay particular attention to Note 1

MAIN MENU SUB MENU OPERATION

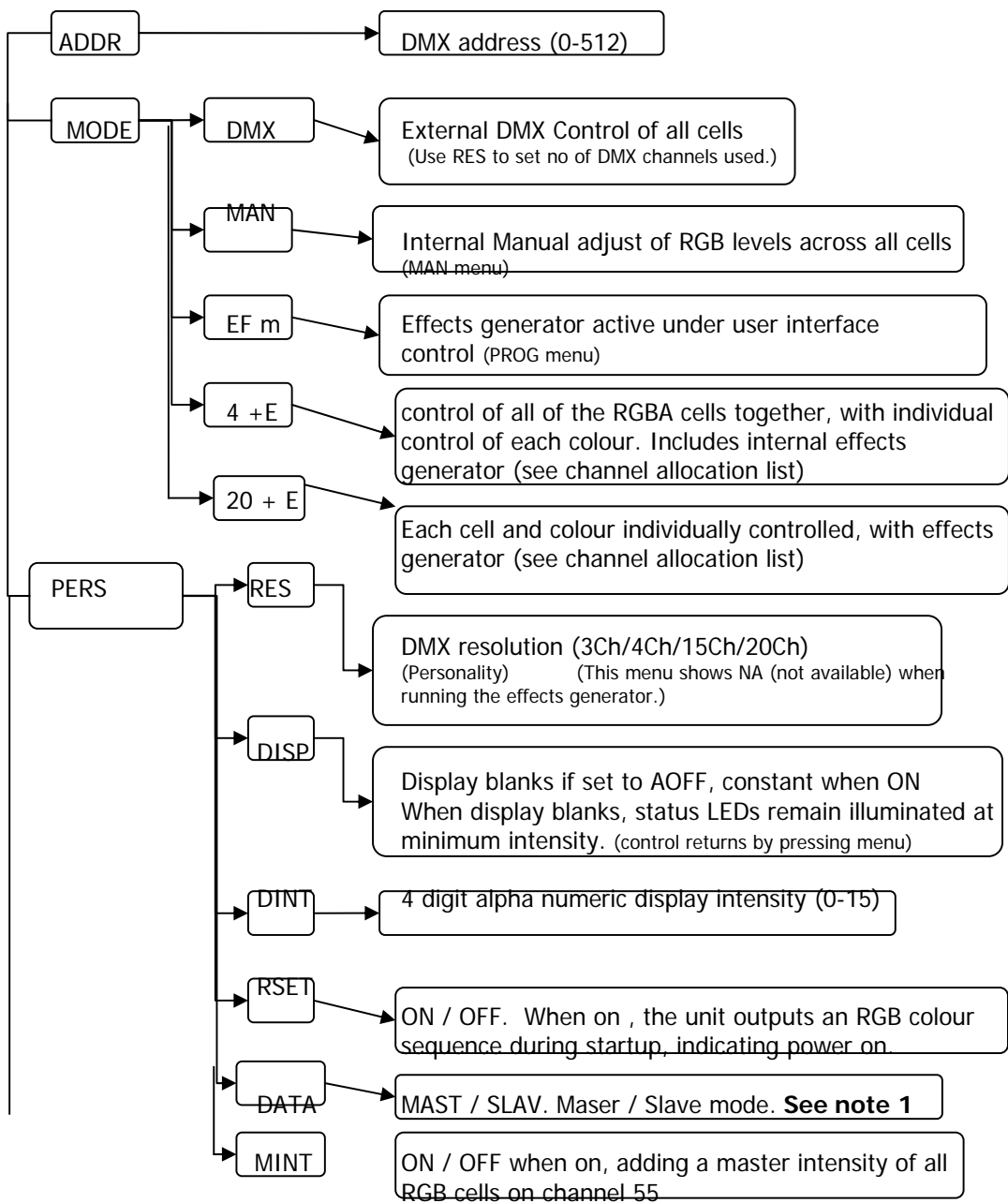

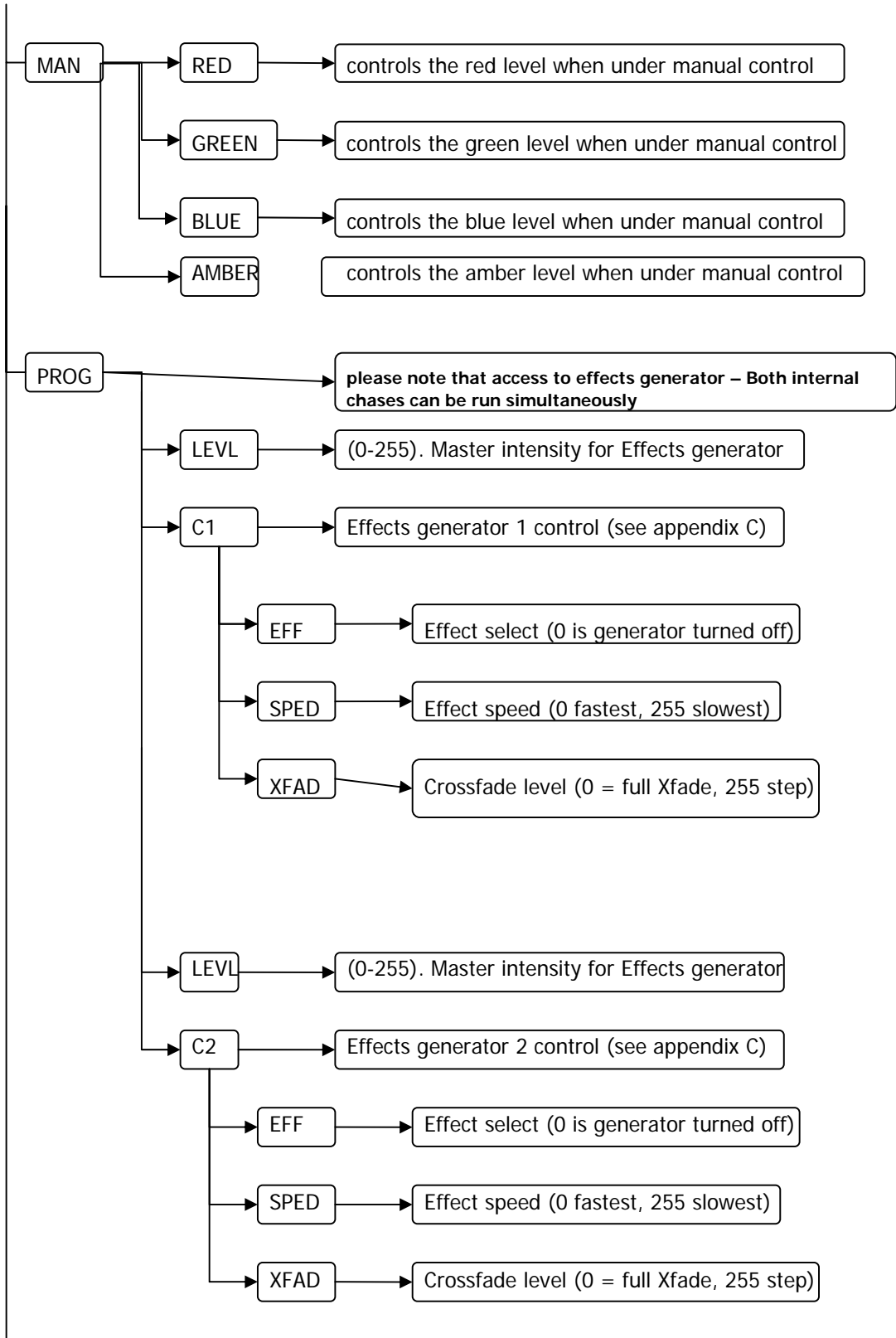

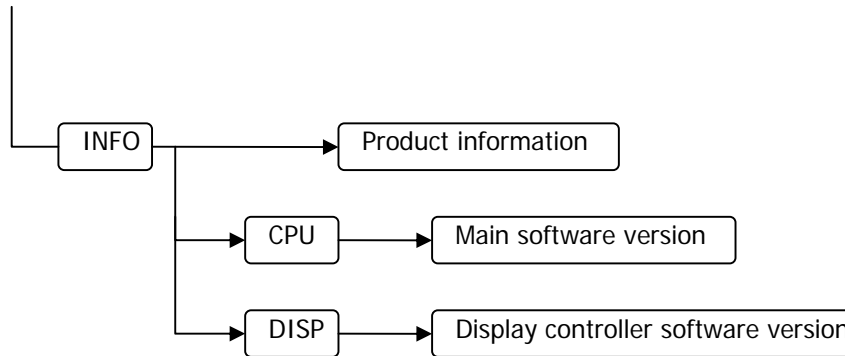

Note 1) MASTER / SLAVE MODE - IMPORTANT

When the Pixelline 110ec is in SLAVE mode, the unit receives and processes DMX data for its control. This mode would be used in normal operation.

When in MASTER mode, the Pixelline 110ec acts as a controller and transmits the 27-28 channels of DMX data generated by the internal effects generator. In this mode, one Pixelline 110ec can be used to synchronize other 110ec's connected to the same DMX data cable.

The standard DMX protocol is used for the data transmission so other lighting products using this control protocol can be driven by a Pixelline 110ec in Master mode.

When a Pixelline 110ec is running in master mode, ensure that no other controller (or other Pixelline 110ec in master mode) is connected to the data on the Pixelline otherwise data corruption will occur.

DMX transmission from the Pixelline110ec only occurs, when the menu of the user interface is at the top of the tree, ie showing the DMX start address Axxx. When the menu system is entered to change operating parameters, DMX transmission ceases. The "Master" pixelline 110ec will work in real-time so the desired effect can be selected using the user interface with the LEDs of the master unit showing the desired effect. Once this is achieved, taking the menu back to the top will initiate DMX transmission and other lighting units connected to the data Pixelline will follow the Master unit.

Data connection

The Pixelline 110ec is fitted with a 5 pin male and female XLR connector, located at each end of the unit, within the recessed mains and data cable entry chamber. This product is capable of receiving USITT DMX512. Wiring code is listed below.

Pin 1	Ground	Pin 2	Data - input
Pin 3	Data + input	Pin 4	not used
Pin 5	not used		

DMX address

'EF M' refers to control of the internal effects generator via the onboard user interface, for stand alone applications. This device will output DMX to other Pixel products or DMX addressable devices.

4+E (four channels plus effects generator) similar to max 2 as with pixelline 1044 unit

channel 1	All Red
channel 2	All Green
channel 3	All Blue
channel 4	All Amber
channel 5	effects select 1
channel 6	speed
channel 7	crossfade
channel 8	effects select 2
channel 9	speed
channel 10	crossfade
channel 11	overall master intensity

20 + E (twenty channels plus effects generator) similar to max 1 in as with pixelline 1044 unit

channel 1	cell 1	Red
channel 2	cell 1	Green
channel 3	cell 1	Blue
channel 4	cell 1	Amber
channel 5	cell 2	Red
channel 6	cell 2	Green
channel 7	cell 2	Blue
channel 8	cell 2	Amber
channel 9	cell 3	Red
channel 10	cell 3	Green
channel 11	cell 3	Blue
channel 12	cell 3	Amber
channel 13	cell 4	Red
channel 14	cell 4	Green
channel 15	cell 4	Blue
channel 16	cell 4	Amber
channel 17	cell 5	Red
channel 18	cell 5	Green
channel 19	cell 5	Blue
channel 20	cell 5	Amber
channel 21	effects select 1	
channel 22	speed	
channel 23	crossfade	
channel 24	effects select 2	
channel 25	speed	
channel 26	crossfade	
channel 27	overall master intensity	

Please note that by introducing master intensity control (mint) (see menu flow chart) this places a master intensity into the channel allocation. This is useful when controlling this device using complex programming via hog/ avolites desks. Personalities for these desks are available from our website. With the introduction of the master intensity the built in effects generator runs shunts down one, thus increasing the channel allocation to 62.

Mechanical information

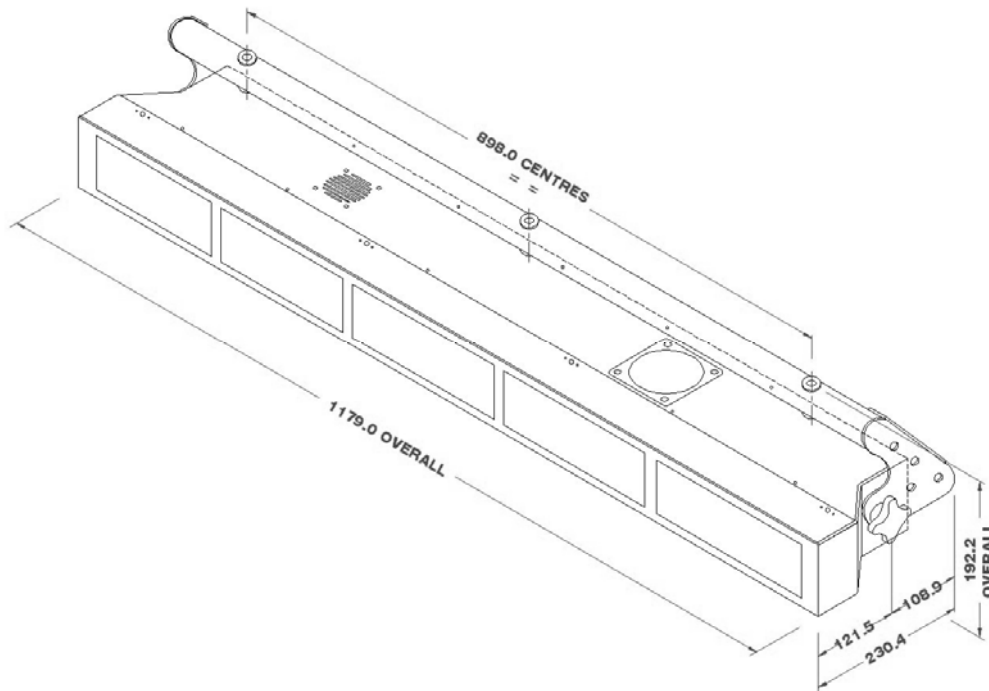

Weight	12 Kg
IP Rating	IP20
Paint finish	Epoxy polyester powder coat
Paint colour	Black standard. White, Polished or anodised aluminium available to order
Floor stands	1 pair supplied with unit
Yoke	Option available at additional cost

Electrical information

Input voltage	100 volts to 250 volts
Power consumption	
Stand by power	7 watts
Maximum power	265watts
Power inlet	16 amp 240 volt 2 pin and earth chassis male with chassis Female located at either end of the product, in a recessed cable entry chamber
Fuse	Anti-surge (T) 5 amp 20mm HBC S505 Series ceramic body

James Thomas Engineering
Navigation Complex
Navigation Road
Diglis Trading Estate
Worcester
WR5 3DE
United Kingdom
Telephone 01905 363 600
Facsimile 01905 363 601
e-mail info@jamesthomas.co.uk
website www.pixelpar.com/ www.pixelrange.co.uk
www.jamesthomas.co.uk

The information contained in this document may be subject to change without notice. The latest update is posted on the website.

James Thomas Engineering Limited makes no warranty of any kind with regard to this material, including but not limited to, the implied warranties of fitness for a particular purpose.

James Thomas Engineering Limited shall not be liable for errors contained herein or for incidental or consequential damages in connection with the furnishing, performance or use of this material. All trademarks are acknowledged.

All brand or product names are trademarks or registered trademarks of their respective owners

